

STARK PRODUCTS COMPANY CONFIDENTIAL AND PROPRIETARY INFORMATION
 THIS DRAWING CONTAINS CONFIDENTIAL AND PROPRIETARY INFORMATION
 YOU MAY NOT:
 1.) DIVULGE IT TO THIRD PARTIES WITHOUT THE EXPRESS PRIOR
 WRITTEN CONSENT OF STARK PRODUCTS CO.,
 OR
 2.) MAKE ANY USE OF IT EXCEPT FOR THE SPECIFIC PURPOSE FOR
 WHICH STARK PRODUCTS CO. HAS MADE IT AVAILABLE TO YOU

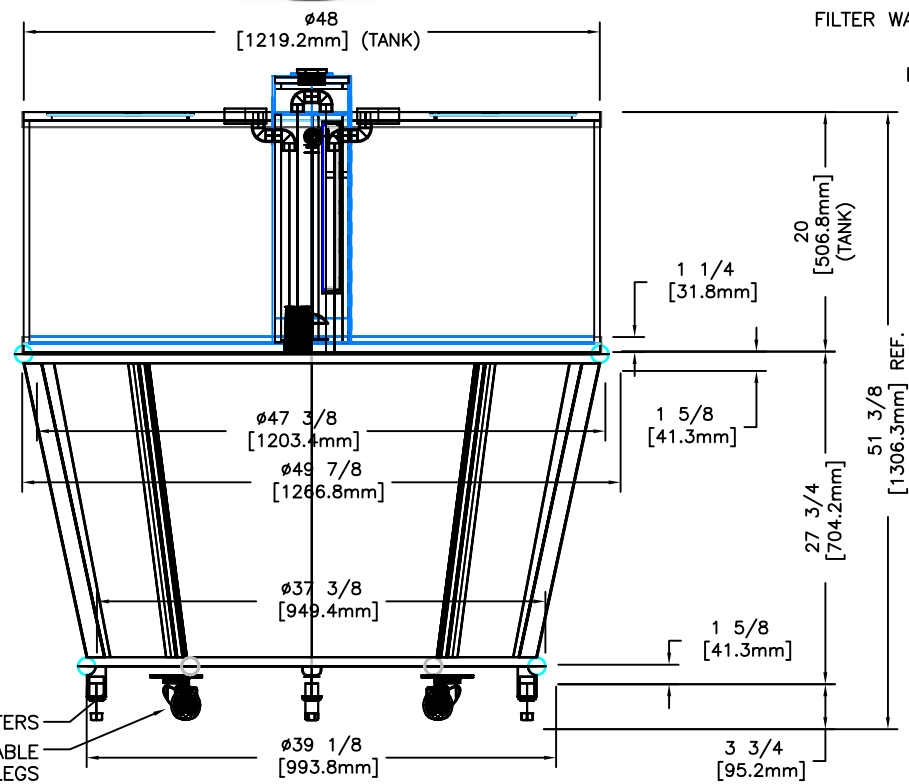

		DATE	STARK PRODUCTS CO., INC. 29-14 122 ST. COLLEGE POINT QUEENS NY 11354				
DRAWN	A.W.	7/28/16					
REVISD			4 FT. CYLINDRICAL TANK				
JOB.No.	SLS-120R						
DWG. No.	SLS-120R		SIZE	CUSTOMER'S NAME:	SHT.	OF	REV.
SCALE	3/4"=1'-0"		A		1	1	

STARK PRODUCTS COMPANY CONFIDENTIAL AND PROPRIETARY INFORMATION
 THIS DRAWING CONTAINS CONFIDENTIAL AND PROPRIETARY INFORMATION
 YOU MAY NOT:
 1.) DIVULGE IT TO THIRD PARTIES WITHOUT THE EXPRESS PRIOR
 WRITTEN CONSENT OF STARK PRODUCTS CO.,
 OR
 2.) MAKE ANY USE OF IT EXCEPT FOR THE SPECIFIC PURPOSE FOR
 WHICH STARK PRODUCTS CO. HAS MADE IT AVAILABLE TO YOU

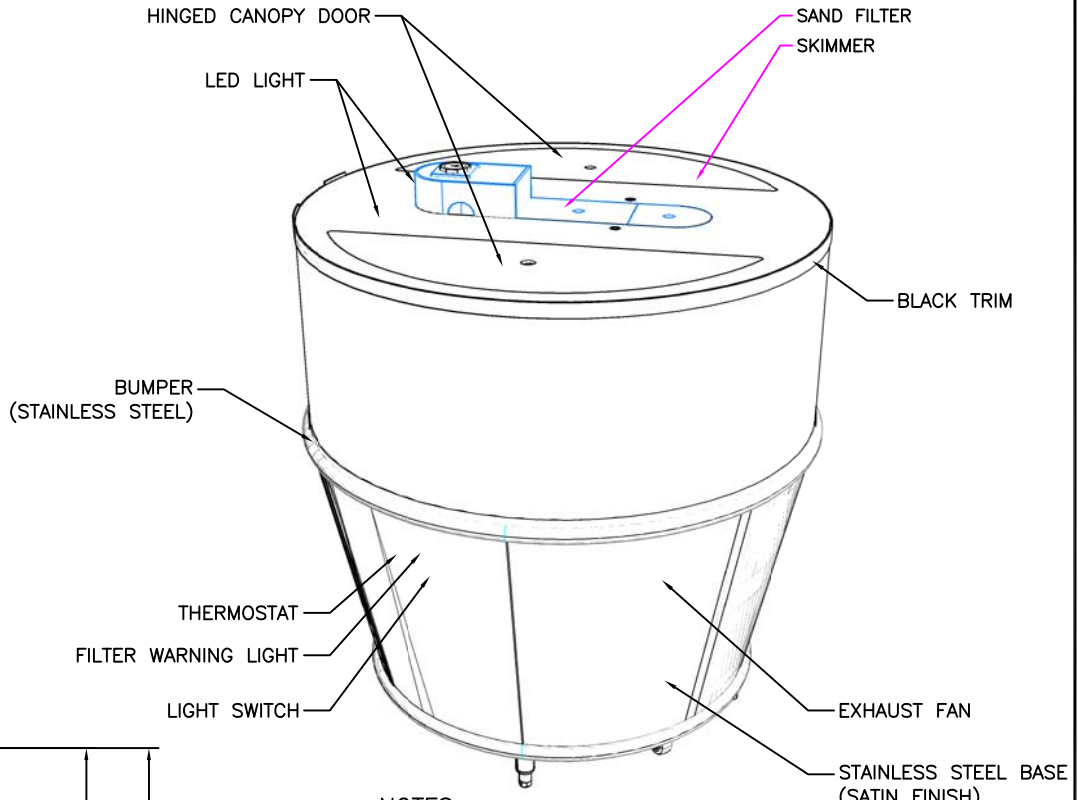
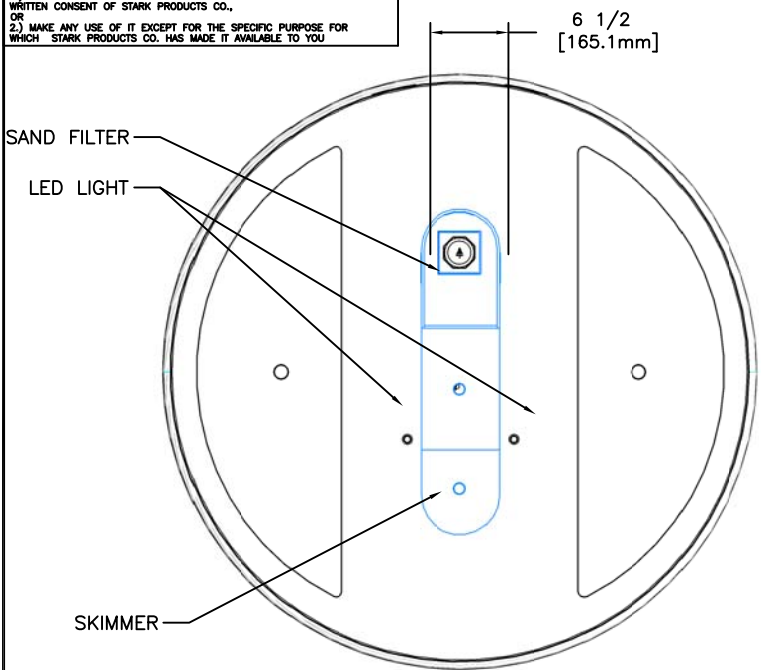

(4x) CASTERS
 (2x) ADJUSTABLE LEVELING LEGS

NOTES:

- TANK EQUIPPED WITH:
 -1/2HP COMPRESSOR (FOR R404A).
 -3/4HP JACUZZI PUMP
 -CHILLER BARREL w/TITANIUM COIL (6,000 BTU/HR).
 -15W ULTRAVIOLET STERILIZER.
- CUSTOMER TO PROVIDE FOR TANK:
 -TWO DEDICATED ELECTRICAL CIRCUITS 115V,20A,60HZ.
 (NO OTHER EQUIPMENT IS TO USE POWER FROM TANK CIRCUITS)
 -FLOOR DRAIN.
- FLOOR DRAIN AND ELECTRICAL OUTLET LOCATIONS TO BE CONFIRMED BY CUSTOMER.
- TANK CAPACITY: 120 GALLONS/LBS. (OF LOBSTERS).
- 1 1/4" (32mm) PVC PIPE RUN INDIRECTLY TO FLOOR DRAIN.

		DATE	STARK PRODUCTS CO., INC.		
DRAWN	A.W.	7/28/16	29-14 122 ST. COLLEGE POINT QUEENS NY 11354		
REVISED			4 FT. CYLINDRICAL TANK		
JOB.No.	SLS-120R				
DWG. No.	SLS-120R		SIZE	CUSTOMER'S NAME:	SHT. OF REV.
SCALE	3/4"=1'-0"		A		1 1